

Cleaning, Maintenance and Storage:

Clean the product with damp cloth and mild detergent. Dry the surface with soft, clean and dry cloth.

When not in use, please store the unit in a dry place with good ventilation.

For more meat processing equipment and sausage seasonings
or to get a free catalog go to www.lemproducts.com
or call 877-536-7763.



Folding Stainless Steel Processing Table Item #1061



LEM Products
109 May Drive • Harrison, OH 45030
877-536-7763 • www.lemproducts.com

Parts Diagram:

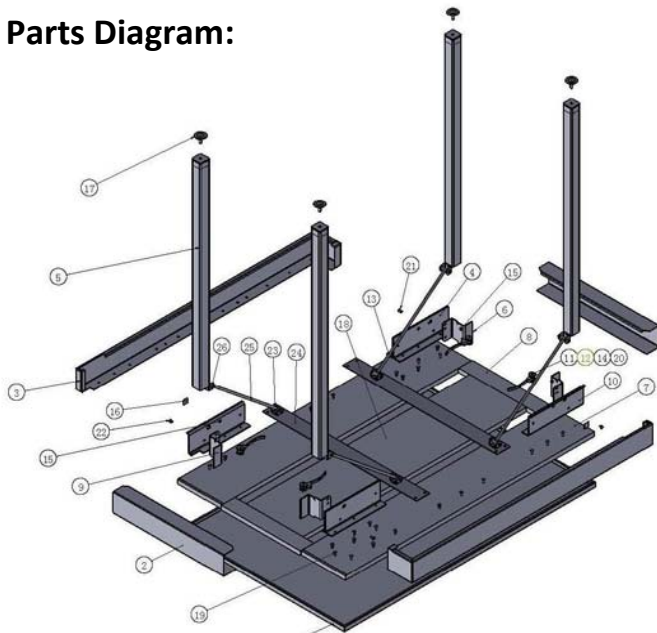

Folding Stainless Steel Processing Table

Parts List:

Part No.	Description	Qty.	Part No.	Description	Qty.
1	Table Top	1 each	14	Locking piece	4 each
2	Short Beam	2 each	15	Magnet	8 each
3	Long Beam	2 each	16	Block piece	2 each
4	Fixing Bracket	2 each	17	Adjustable Foot	4 each
5	Leg	4 each	18	Medium Wood Block	1 each
6	Fixing Bracket	2 each	19	Bolt M5 X 16	34 each
7	Long Wood Block	2 each	20	Washer	8 each
8	Short Wood Block	2 each	21	Long Rivet	2 each
9	Fixing Bracket	2 each	22	Short Rivet	2 each
10	Fixing Bracket	2 each	23	Support Bracket	8 each
11	Rotary Pin	4 each	24	Plate of support bracket	2 each
12	Rotary Bracket	8 each	25	Support	4 each
13	Fixing Bracket	2 each	26	Long pin	8 each

Technical Specifications:

Table Top:	Stainless Steel
Max Loading Capacity:	500 lbs. (227kg)
Overall Dimensions:	45 in. L x 30 in.W x 36 in. H (1140 X 760 X 910mm)

Warning!

1. Maximum loading capacity is 500 lbs. Never overload!
2. Read and understand all instructions. Failure to follow the instructions may cause damage to the product and personal injury!
3. Before using the table, make sure the legs are firmly secured and locked in position.

Operation Instructions:

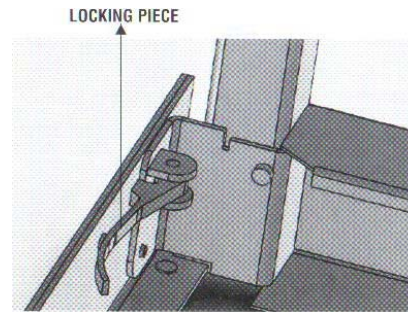

FIG. 01

1. Before using the table, lay the table on the floor upside down.
2. Unfold legs and secure the locking piece(#14) located near the leg in position. The legs should stand firmly upright. If a leg is not securely locked, it could fold unexpectedly and cause damage or injury. (FIG. 01 shows the locking piece in locking position)
3. After all 4 legs are secured in a standing position, turn the table right side up.
4. Lock Rotary Pin (#11) tightly.
5. Attach Adjustable Foot (#17) on the leg (#5). If needed, adjust feet on leg to level table.
6. To close and fold the table, reverse the above procedures.