

IMPORTANT WARRANTY INFORMATION — PLEASE READ

THIS WARRANTY COVERS THE LEONARDI MEAT GRINDERS, TOMATO STRAINERS (MANUAL OR ELECTRIC APPLICATION), AND SAUSAGE STUFFING MACHINES. THE WARRANTY IS EXTENDED TO THE ORIGINAL PURCHASER OF THE PRODUCT.

WARRANTY DURATION:

This product is warranted to the original purchaser for a period of one (1) year from the original purchase date. EACH UNIT COMES WITH A WARRANTY CARD, WHICH MUST BE FILLED OUT COMPLETELY AND RETURNED IMMEDIATELY, WITH PROOF OF PURCHASE RECEIPT. FAILURE TO RETURN THE WARRANTY CARD AFTER PURCHASE WILL LIMIT WARRANTY TO 90 DAYS WITH PROOF OF PURCHASE.

WARRANTY COVERAGE:

This product is warranted against defective materials or workmanship. This warranty is void if the product has been damaged by accident, misuse, neglect, modification or improper service or repairs by unauthorized personnel. It is also void if damaged in shipment or by other causes not arising out of defects in the materials or workmanship. This warranty is effective only if the product is purchased and operated in the U.S.A. and does not extend to any units which have been in violation of written instructions furnished, or to units which have been altered or modified.

WARRANTY DISCLAIMERS:

This warranty is in lieu of all warranties expressed or implied, and no representative or person is authorized to assume any other liability in connection with the sale of our products. There shall be no claims for defects or failure of performance under any theory of sort, contract or commercial law including, but not limited to negligence, gross negligence, strict liability or breach of contract.

WARRANTY PERFORMANCE:

During the above one-year warranty period, a product with a defect will be either repaired or replaced after the product has been inspected by our Service Department Technician. NO PRODUCT WILL BE EVALUATED UNLESS THE ORIGINAL SALES RECEIPT OR THE WARRANTY CARD IS ON FILE. The repaired product will be in warranty for the balance of the one-year warranty period and an additional on-month period. No charge will be made for such repair or replacement.

IMPORTANT NOTICE:

If any parts are missing or defective, please contact our Customer Service Department for assistance at 877-536-7763 (M-F 8:30am – 5:00pm EST) DO NOT RETURN TO THE STORE WHERE THE UNIT WAS PURCHASED.

CONSUMER SERVICE:

The Leonardi product line (Electric Meat Grinders, Sausage Stuffing Machines and Tomato Strainers) is distributed in the U.S.A. exclusively by L.E.M. Products, Inc., 107 May Drive, Harrison, OH 45030. Phone: 877-536-7763 Fax: 513-202-9494.

MERCHANDISE RETURN POLICY/WARRANTY SERVICE:

To obtain service under terms of this warranty, first request an authorization by contacting our office at 877-536-7763 prior to sending the merchandise back. No merchandise will be accepted without prior authorization. Please return the product pre-paid in the original packaging if possible, enclose a copy of your receipt (keep a copy of your proof-of purchase for your records) and include a written explanation of the issue you are experiencing. Ship to L.E.M. Products, Inc., 107 May Drive, Harrison, Ohio 45030. L.E.M. Products, Inc. is not responsible for damage incurred in shipping. Pack product securely.



TOMATO SQUEEZER

USE AND MAINTENANCE INSTRUCTIONS

PLEASE READ BEFORE OPERATING EQUIPMENT

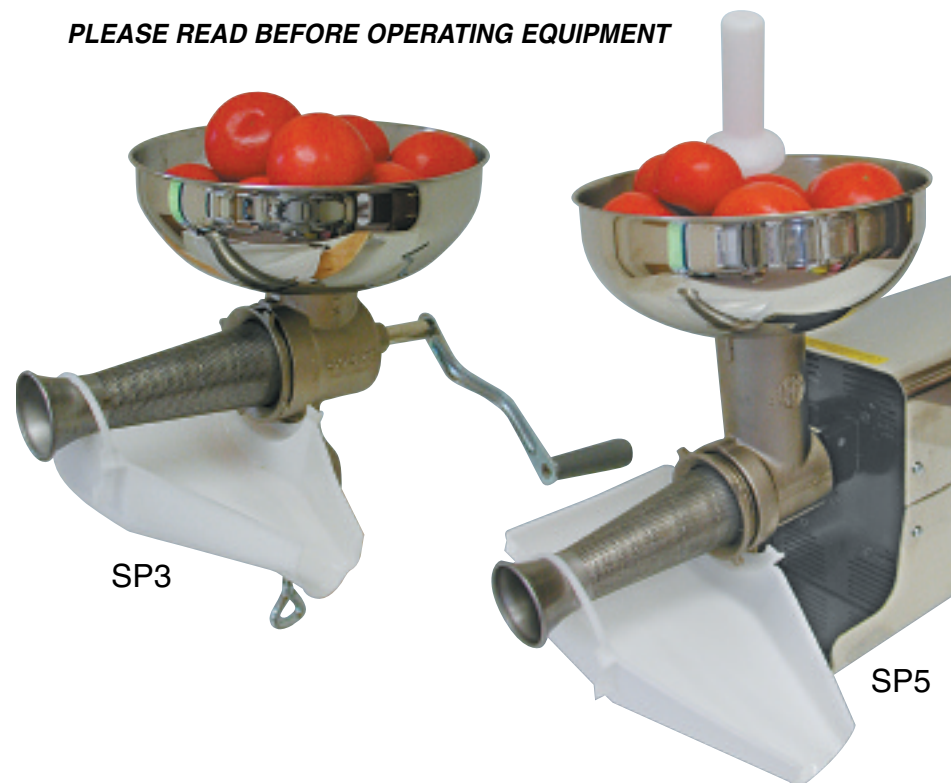

SP3

SP5



FABIO LEONARDI

L.E.M. Products, Inc. is the exclusive distributor for Leonardi in the U.S.A.

L.E.M. Products, Inc.
107 May Drive, Harrison, OH 45030
877-536-7763 www.lemproducts.com

The manufacturer declines all responsibility for damage to persons, things or animals arising from the failure to comply with the norms contained in the sheet attached to the machine. The manufacturer reserves the right to make modifications at anytime to the models while maintaining the main characteristics described herein. The manufacturer also declines all responsibility for any errors in compiling this illustration sheet.

USE AND MAINTENANCE INSTRUCTIONS

Technical Characteristics

The unit comprises a body, a 18/10 stainless steel filter, a double threaded screw feeder and a heavy cast iron ring treated with special resins.

USE

It is ideal for squeezing both unprocessed or boiled tomatoes and other fruit and vegetables suitable for producing juices, purees and conserves.

PRINCIPLES OF OPERATION

Put the fruit or vegetables (without stones or stalks) into the hopper and press it into the body of the machine using the stomper provided. The screw feeder, rotating about its axis will push it forward and press it against the filter. The juice will come out of the holes in the filter and fall into the chute which conveys it to the collection receptacle. The seeds and peels are eliminated through the small funnel on the end of the filter. It is possible to put the seeds and skins back into the machine in order to obtain an improved squeezing.

ASSEMBLY INSTRUCTIONS

Before first use, wash all parts with hot soapy water, rinse thoroughly and dry. To attach the tomato squeezer it is recommended to dismantle it into its various components and to first attach the body (1), then insert the drive unit (3), the screw feeder (7) and lastly the filter (9) and pressing firmly until the ring (8) is positioned on the thread of the body (left hand thread). Finally, plug in the motor and start it in order to completely tighten the ring. Screw on the hopper (12) and mount the chute (10) and affix it with the brace (11).

USE AND MAINTENANCE NORMS

- Introduce the foodstuffs into the body using only the stomper provided.
- To facilitate the introduction of unprocessed tomatoes into the hopper it is advised to invert the stomper and use the handgrip.
- Do not introduce fruit or vegetables containing stones or stalks.
- Avoid running the machine empty.
- After use, wash all parts of the machine, both internal and external, with hot soapy water and dry thoroughly.
- Keep the drive unit lubricated.

MANUAL UNITS

Follow the assembly instructions enclosed. Mount assembled unit on the edge of a table or counter more than two inches thick.

PREPARATION

Wash fruit or vegetables prior to processing. Cut into pieces small enough to fit into throat of machine. Put the fruit or vegetables (without stones or stalks) into the hopper. Using the stomper, press the fruit or vegetables into the body of the machine. You will need two bowls. Place one bowl at the end of the filter to catch the waste material. Place the other bowl under the chute to catch the juice. Only the juice and meat of the produce will process into the filter and fall into the chute. You can put the seeds and skins back into the hopper for a second pressing to obtain additional juice.

HOW TO OPERATE

If you have a manual style unit, turn the handle and let the squeezer do the work.

If you have a unit that attaches to your electric meat grinder, follow the instructions above. If your electric grinder has forward and reverse speeds, make sure it is in the FORWARD SPEED. Avoid running the machine empty.

CLEAN UP AND MAINTENANCE: After use, wash all parts of the machine, both internal and external, with hot soapy water and dry thoroughly. Wash by hand. DO NOT put parts in the dishwasher. Keep the DRIVE SHAFT (part #5) lubricated.

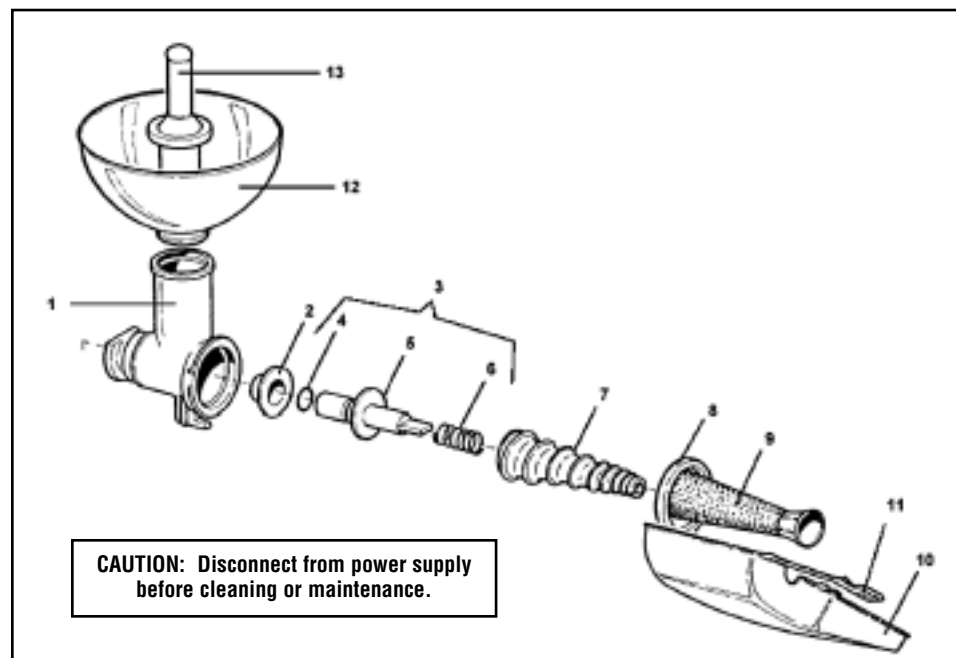

Parts List — Tomato Squeezer (SP3 & SP5)

Ref.	Description	Ref.	Description
1	Body	8	Ring
2	Bushing	9	Ring filter
3	Complete drive unit	10	Chute
4	O-Ring	11	Chute brace
5	Drive shaft	12	Hopper
6	Drive spring	13	Stomper
7	Screw feeder		