

THE LEADER IN GAME PROCESSING



PROFESSIONAL JERKY SLICER & TENDERIZER

USE & MAINTENANCE

602T, 602J, 602TJ, 433T, 433J & 433TJ



ATTENTION:

If any components of this unit are broken,
or if the unit does not operate properly,
please contact LEM Products at

1-877-536-7763

For more great products or a free catalog
log onto www.lemproducts.com



**1 YEAR
WARRANTY**

⚠ GENERAL WARNINGS AND SAFETY INFORMATION ⚠

IT IS IMPORTANT TO READ AND UNDERSTAND ALL OF THE INSTRUCTIONS AND SAFEGUARDS PRIOR TO USE

1. Always ensure that the appliance is properly assembled and safely set up before use.
2. **DO NOT** leave the appliance unattended if it can be switched on and operated.
3. **CAUTION:** This appliance is not recommended for use near or by children or persons with certain disabilities. Set up and store the appliance out of reach of children. When not in use, store device in a secure and dry place out of reach of children.
4. Store appliance in upright position to extend life of motor.
5. **WARNING:** Heavy object, to avoid muscle strain or back injury, use lifting aids and proper lifting techniques when moving appliance.
6. The appliance must be connected to an 120V AC electric supply only.
7. For your safety, this unit is equipped with a 3-pronged, grounding plug and must be plugged into a properly grounded outlet. If your outlet is not of the proper type, it is your responsibility to have the outlet and wiring changed to the correct type. Do not cut off the third (grounding) prong. Do not use an adapter.
8. Using this appliance with an extension cord may cause a decrease in electrical current, causing the motor to be over worked and possibly catch fire.
9. Do not operate with a damaged cord or plug, after the unit malfunctions, has been damaged in any way or if appliance has been immersed in water or other liquid. Return unit to LEM Products for assessment and repair.
10. Always unplug unit when not in use, when changing parts or cleaning.
11. Never unplug by pulling on the power cord, always pull directly on the plug itself.
12. Do not let cord hang over edge of table or counter, contact sharp edges or touch hot surfaces.
13. Indoor use only. To protect against the risk of electrical shock, never immerse the device in water and do not expose the device to rain or moisture. **WARNING:** In the event the device should fall into water, remove the plug from the wall socket before attempting to remove the unit from the water. If submergence occurs, have the appliance examined by an authorized technician before use.
14. To protect against the risk of electrical shock, **DO NOT** use the appliance if your hands are wet or if you are standing on a wet floor. **DO NOT** use the appliance if it is wet or moist. **DO NOT** operate this device with wet hands or bare feet. **DO NOT** operate near running water.
15. The appliance is designed for domestic use and not for commercial purposes.
16. **DO NOT** use the appliance on bones, deep frozen food, hard items or non-food items.
17. Use the appliance with the supplied accessories only. **WARNING:** The use of attachments not recommended or sold by the manufacturer may cause injury, damage to personal property, and may void your warranty.
18. **WARNING:** Do not use while under the influence of alcohol or drugs (prescription or non-prescription) as these may impair user's ability to properly assemble or safely operate the appliance.
19. The manufacturer declines any responsibility in the case of improper use of this product. Improper use of this product voids the warranty.
20. Avoid contacting moving parts. Wait until all parts have come to a complete stop and disconnect from the power source before removing any parts of the appliance.
21. **DO NOT** operate the appliance without the upper case installed.
22. **DO NOT** use fingers to push meat into appliance while the unit is running, doing so may cause serious injury.
23. Thoroughly hand-wash all parts in warm soapy water prior to use. **DO NOT SOAK. NOT DISHWASHER SAFE** (discoloration may occur).
24. Tie back loose hair and clothing. Remove neckties, rings, watches, bracelets or other jewelry before operating the appliance.
25. Use on a level, stable surface to prevent tipping. Never move the appliance while in use.
26. **WARNING:** Knives are **SHARP!** To avoid injury, use extreme caution when handling.
27. When unit is turned off, cooling fan will no longer operate. **DO NOT** touch housing during cool down period. Housing will take a few minutes to cool down after unit is turned off.

28. SAVE THESE INSTRUCTIONS

IMPORTANT WARRANTY INFORMATION PLEASE READ FILL OUT AND RETURN ENCLOSED WARRANTY CARD

THIS WARRANTY COVERS:

LEM Professional Jerky Slicer and Tenderizer Attachment with .35HP Motor
#433TJ, #433T, #433J, #602TJ, #602T, #602J

THE WARRANTY IS EXTENDED TO THE ORIGINAL PURCHASER ONLY

WARRANTY DURATION: This product is warranted to the original purchaser for a period of one (1) year from the original purchase date. **EACH UNIT COMES WITH A WARRANTY CARD, WHICH MUST BE FILLED OUT COMPLETELY AND RETURNED IMMEDIATELY, WITH A COPY OF THE PURCHASING RECEIPT. FAILURE TO RETURN YOUR WARRANTY CARD WILL LIMIT WARRANTY TO 90 DAYS WITH PROOF OF PURCHASE.**

WARRANTY COVERAGE: This product is warranted against defective materials or workmanship. The warranty is void if the product has been damaged by accident, misuse, neglect, modification or improper service or repairs by unauthorized personnel. It is also void if damaged in shipment or by other causes not arising out of defects in the materials or workmanship. This warranty does not extend to any units which have been in violation of written instructions furnished. This warranty covers only the product and its specific parts, not food or other products processed in it.

WARRANTY DISCLAIMERS: This warranty is in lieu of all warranties expressed or implied, and no representative or person is authorized to assume any other liability in connection with the sale of our products. There shall be no claims for defects or failure of performance under any theory of sort, contract or commercial law including, but not limited to negligence, gross negligence, strict liability or breach of contract. The manufacturer declines all responsibility for damage to persons, things or animals arising from the failure to comply with the norms contained in this manual. The manufacturer reserves the right to make modifications at anytime to the models while maintaining the main characteristics described herein. The manufacturer also declines all responsibility for any errors in compiling this manual.

WARRANTY PERFORMANCE: During the above one year warranty period, a product with a defect will either be repaired or replaced after the product has been inspected by an LEM Service Technician. **LEM RESERVES THE RIGHT TO REFUSE WARRANTY PERFORMANCE OR PRODUCT EVALUATION UNLESS THE ORIGINAL SALES RECEIPT OR THE WARRANTY CARD IS ON FILE.** The repaired product will be in warranty for the balance of the one year warranty period. No charge will be made for such repair or replacement.

IMPORTANT NOTICE: If any parts are missing or defective, please contact our Customer Service Department for assistance at 877-536-7763 (M-F 8:30am to 4:30pm EST). **DO NOT RETURN TO THE STORE WHERE THE PRODUCT WAS PURCHASED.**

LEM PRODUCTS MERCHANDISE RETURN POLICY WARRANTY SERVICE: To obtain service under terms of this warranty, please contact us at 877-536-7763 to obtain authorization prior to returning the merchandise. No merchandise will be accepted without prior authorization. Please return the product prepaid in the original packaging if possible, enclose a copy of your receipt, (keep a copy of your proof-of-purchase for your records) and include a written explanation of the issue. Ship to LEM Products, 4440 Muhlhauser Road, Suite 300, West Chester, OH 45011. LEM Products is not responsible for damage incurred in shipping, make certain to pack product properly. Return shipping charges are the responsibility of the purchaser. Packages returned to LEM should be insured for the value of the product to cover any damages that may occur during shipping.

Revised November 20, 2015

INSTALLMENT & OPERATION

TO INSTALL ATTACHMENT TO MOTOR:

1. Align the drive of the motor with the hub (#9) and drive shaft (#11C) of the slicer/tenderizer attachment and tighten the star bolt (on motor) securely.
2. Insert the two meat combs (#1) into the slots in the top of the upper housing (#3) – one comb on each side of the upper case. The combs should slide easily into the holes between the drive and driven shafts. When inserted properly, the combs will be visible from the bottom of the lower case (#8).

OPERATING INSTRUCTIONS OF ATTACHMENT UNIT:

Read these instructions before operating jerky slicer/tenderizer attachment.

1. Drop meat through the opening of the cover. DO NOT attempt to force meat into the opening. Rolling action of the knives will carry appropriately sized portions of meat into the unit.
2. Use boneless cuts of meat only. Meat should not exceed 1 1/4" thickness. Remove gristle and bone before tenderizing/slicing to eliminate clogging or stalling.
3. For tenderizer attachment: run meat through tenderizer twice at a 90 degree angle to experience the maximum tenderness.



WARNING



Keep hands clear from bottom of attachment! Allow meat to fall out- do not attempt to pull it out! Serious injury could occur!

CIRCUIT BREAKER INFORMATION

Your LEM motor is equipped with a circuit breaker to protect the unit. In the event of a power disruption, abnormal operation or over heating, the motor will temporarily shut down to prevent damage. If this should happen, follow the seven steps listed below:

Step 1: Turn On/Off switch to off.

Step 2: Unplug unit.

Step 3: Check inside of unit and remove any obstruction.

Step 4: Wait 1 or 2 minutes, then plug unit into wall outlet again.

Step 5: Push Restart Button and release. Located on back panel of motor.

Step 6: Turn switch on.

Step 7: Resume operation.

TROUBLESHOOTING

If your unit fails to operate, contact LEM Products for technical assistance. Do not attempt to repair or adjust any electrical or mechanical functions on this unit without contacting an LEM technician. Doing so will void warranty. Servicing should be performed as directed by qualified personnel only.

LEM Products Technical Assistance: Toll Free at 877-536-7763.

⚠ WARNING SHARP BLADE ⚠

**When Handling the Shafts, hold by the Gear and Bushing Ends!
It is recommended to wear cut resistant gloves!**

BEFORE USE

1. Wash all parts in hot soapy water. This will remove any residue and dirt left from the manufacturing process. Keep water away from electrical motor.
2. Handle the SHAFTS by holding both ends to avoid sharp edges.
3. Rinse and dry thoroughly.
4. **DO NOT PUT PARTS IN A DISHWASHER.**
5. **DO NOT SOAK HOUSING OF THE ATTACHMENT.**

CLEANING & MAINTENANCE

1. Turn unit off and remove plug from wall outlet.
2. Remove attachment from motor by loosening star bolt (on motor).
3. Remove meat combs (#1).
4. Remove thumbscrews (#2).
5. Remove upper case (#3).
6. Remove the drive and driven cutter shafts. **WARNING: BLADES ARE SHARP!**
7. Wash with hot soapy water. Rinse and dry parts thoroughly.
8. **DO NOT SOAK UPPER (#3) AND LOWER (#8) CASE.**

TO REASSEMBLE AFTER CLEANING:

1. Put the drive shaft (#13A) into position first.
2. Put the driven shaft (#4A or #4B) into position next.
3. Make sure the gears (#14) are properly aligned and mesh.
NOTE: If gears are not in alignment, unit will malfunction which could cause injury and will void the manufacturers' warranty.
4. Replace upper case (#3) and secure with thumbscrews (#2).
WARNING: DO NOT USE WITHOUT UPPER CASE INSTALLED.

DISASSEMBLY:

Over time, meat will wedge between the knives and spacers. Occasionally the drive and driven rollers should be disassembled, and each piece washed thoroughly.

Start disassembly by:

1. Take notice of how the blades are assembled - possibly take a digital picture to refer to.
2. Remove C-Clip (#15) on the end opposite the gear.
3. Slide all remaining parts off to be hand washed.

* View video at <http://www.lemproducts.com/product/2-in-1-jerky-tenderizer-slicer-attachment-for-grinders/butcher-meat-tenderizers>

433TJ PARTS LIST & DIAGRAM

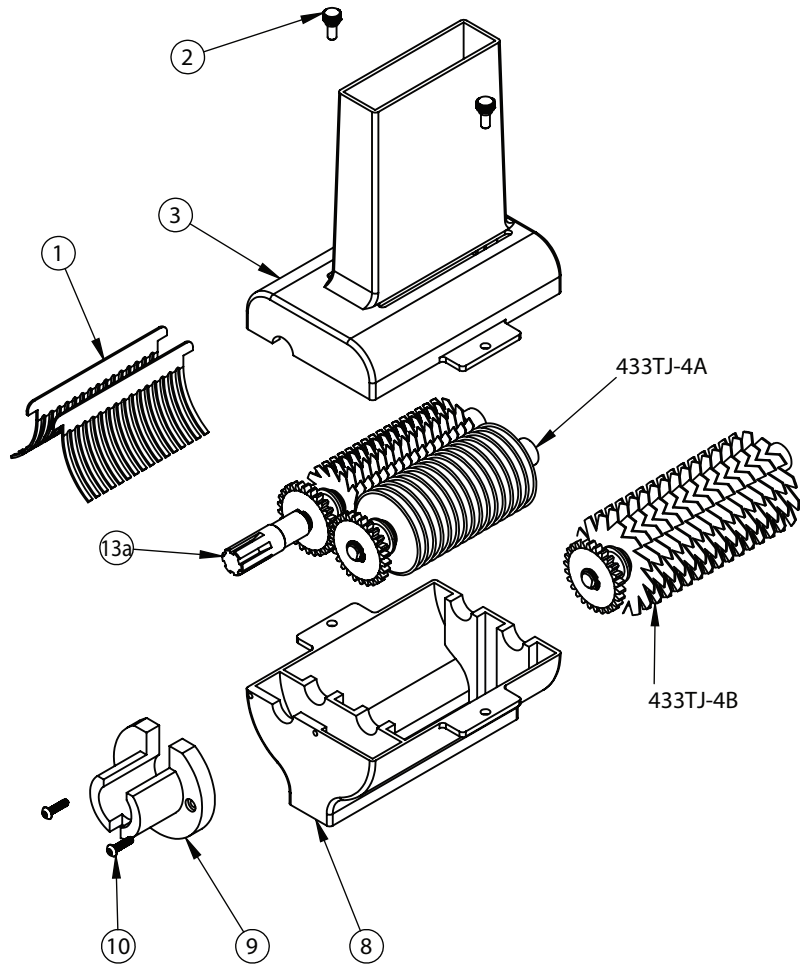

Part #	Qty	Description
433TJ - 1	2	Comb
433TJ - 2	2	Thumb Screw
433TJ - 3	1	Case - Upper
433TJ - 4A	1	Driven Shaft Assy (SLICER)*
433TJ - 4B	1	Driven Shaft Assy (TENDERIZER)**
433TJ - 8	1	Case - Lower
433TJ - 9	1	Hub
433TJ - 10	2	Hub Screw
433TJ - 13A	1	Drive Shaft Assembly

*433TJ, 433J, 602TJ, 602J

**433TJ, 433T, 602TJ, 602T

.35HP MOTOR DIAGRAM

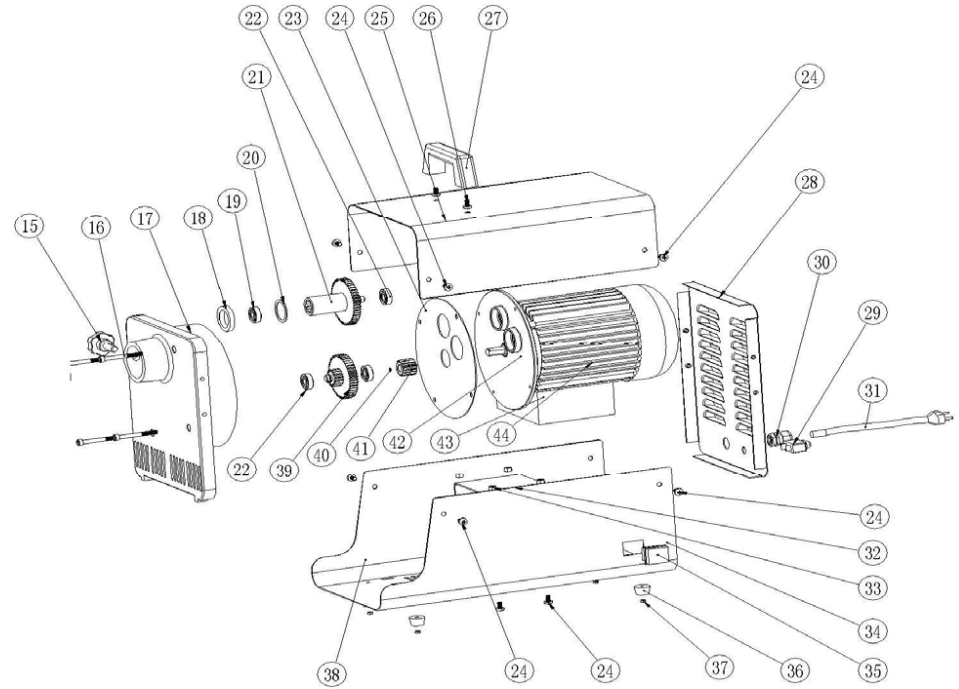

.35HP MOTOR PARTS LIST

*Sold with 602TJ, 602T, and 602J

Part #	Description	Qty
15	Star Bolt	1
16	Allen Screws M6 for Front Panel	4
17	Front Panel	1
18	Grease Seal	1
19	Roller Bearing	1
20	Main Washer	1
21	Main Gear	1
22	Bearing	3
23	Rubber Pad	1
24	Screws	10
25	S/S Upper Housing	1
26	Handle Screw	2
27	Handle	1
28	Back Panel	1
29	Circuit Breaker	1
30	Fastener for the Power Cord	1
31	Power Cord	1
32	Brace	1
33	Allen Screw M6 for Brace	2
34	S/S Lower Housing	1
35	Switch	1
36	Plastic Feet	4
37	Allen Screw M4	6
38	Philips Screw M4 for Feet	5
39	Step Gears	1
40	Clip Spring	1
41	Pinion Gear	1
42	Front Panel of the Motor	1
43	Electric Box	1
44	Motor	1

433TJ - 13A DRIVE SHAFT ASSEMBLY

* Drive shaft assembly In the 433TJ, 433T, 433J, 602TJ, 602T, and 602J

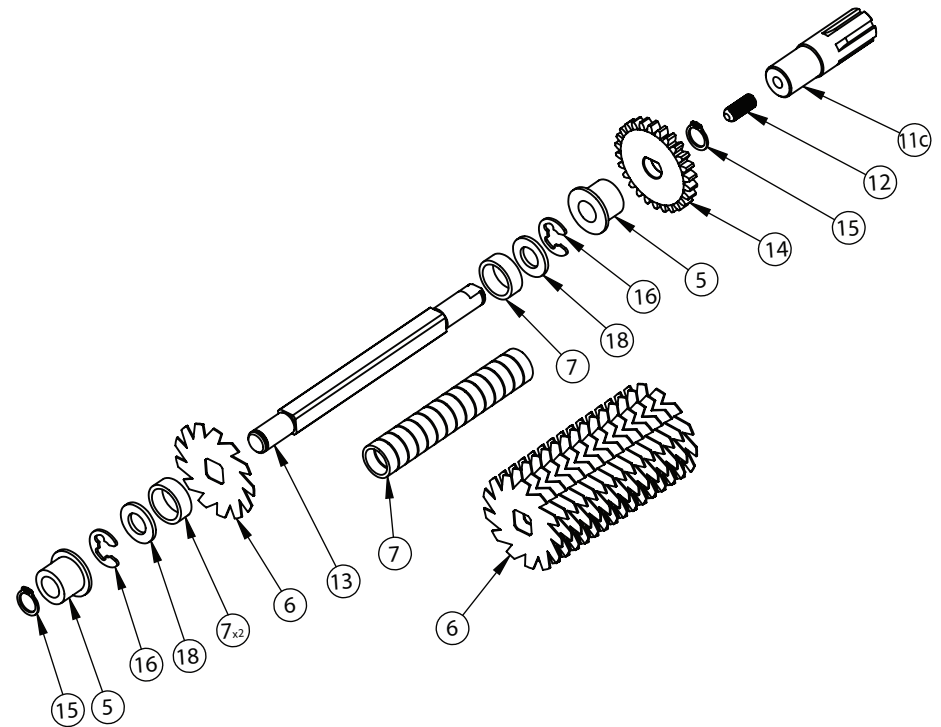

Part #	Qty	Description
433TJ - 5	6	Bushing, Nylon
433TJ - 6	30	Knife Tenderizer
433TJ - 7	93	Spacers
433TJ - 11C	1	Drive Shaft Adapter
433TJ - 12	1	Set Screw
433TJ - 13	1	Drive Shaft
433TJ - 14	3	Gear
433TJ - 15	6	Lock Ring, (C-Clip)
433TJ - 16	6	E Retainer Ring
433TJ - 18	5	SS Washer (13 mm)
433TJ - 19	1	SS Washer (20mm)

ASSEMBLY

!! DO NOT ASSEMBLE WITHOUT CAREFULLY READING THE INSTRUCTIONS BELOW!!

433TJ - 4B JERKY TENDERIZER DRIVEN SHAFT ASSEMBLY

The 433TJ / 602TJ can be used as a jerky slicer (the drive shaft has tenderizer blades, and the driven shaft has slicer blades) or as a tenderizer (both shafts have tenderizer blades). These must be assembled correctly, or the unit will not function.

FOR TENDERIZING: 433TJ, 433T, 602TJ, 602T

The spacers must be positioned so the tenderizer blades on the drive shaft and the tenderizer blades on the driven shaft are one spacer apart. This is accomplished by placing an extra nylon spacer (#7) nearest the gear on the driven shaft. This will offset the tenderizer knives by about 1/8". Be sure the direction of the knives on both shafts is correct, i.e. the pointed edge should be on the back edge of the cutting action.

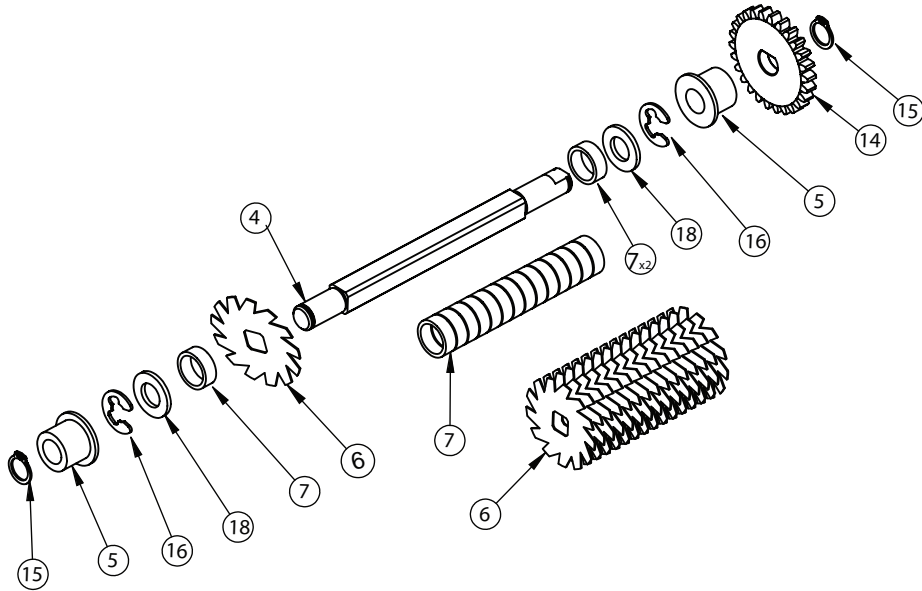

Part #	Qty	Description
433TJ - 4	2	Driven Shaft
433TJ - 5	6	Bushing, Nylon
433TJ - 6	30	Knife Tenderizer
433TJ - 7	93	Spacers
433TJ - 11C	1	Drive Shaft Adapter
433TJ - 12	1	Set Screw
433TJ - 13	1	Drive Shaft

Part #	Qty	Description
433TJ - 14	3	Gear
433TJ - 15	6	Lock Ring, (C-Clip)
433TJ - 16	6	E Retainer Ring
433TJ - 17	15	Knife-Slicer
433TJ - 18	5	SS Washer (13 mm)
433TJ - 19	1	SS Washer (20mm)

ASSEMBLY

!! DO NOT ASSEMBLE WITHOUT CAREFULLY READING THE INSTRUCTIONS BELOW!!

433TJ - 4A JERKY SLICER DRIVEN SHAFT ASSEMBLY

FOR SLICING: 433TJ, 433J, 602TJ, 602J

The spacers (#7) must be assembled exactly the same on both shafts so the tenderizer blades and the slicer blades are adjacent to each other. The tenderizer blades have a notch in the square opening, so always line these up after washing. They also have a cutting direction (see schematic). The pointed side should always be on the back edge of the cutting action. The slicer blades also have a direction. They are sharpened on only one edge, so they have a bevel. The direction of the bevel should be the same for all the knives as shown in Detail A on the schematic. Always install the flat side toward the gear end of the shaft. When installing the driven shaft (#4A) in the unit, always place the flat side of the slicer blade against the tenderizer blade. If you place the bevelled edge against the tenderizer blade, the unit will not slice properly.

