

**IMPORTANT WARRANTY INFORMATION PLEASE READ  
FILL OUT AND RETURN ENCLOSED WARRANTY CARD**

THIS WARRANTY COVERS  
LEM Craftsmen Tenderizer #682  
THE WARRANTY IS EXTENDED TO THE ORIGINAL PURCHASER ONLY.

**WARRANTY DURATION:** This product is warranted to the original purchaser for a period of one (1) year from the original purchase date. **EACH UNIT COMES WITH A WARRANTY CARD, WHICH MUST BE FILLED OUT COMPLETELY AND RETURNED IMMEDIATELY, WITH A COPY OF THE PURCHASING RECEIPT. FAILURE TO RETURN YOUR WARRANTY CARD WILL LIMIT WARRANTY TO 90 DAYS WITH PROOF OF PURCHASE.**

**WARRANTY COVERAGE:** This warranty covers only the product and its specific parts, not food or other products processed in it. This product is warranted against defective materials or workmanship. The warranty is void if the product has been damaged by accident, misuse, neglect, modification or improper service or repairs by unauthorized personnel. It is also void if damaged in shipment or by other causes not arising out of defects in the materials or workmanship. This warranty does not extend to any units which have been in violation of written instructions furnished. This warranty covers only the product and its specific parts, not food or other products processed in it.

**WARRANTY DISCLAIMERS:** This warranty is in lieu of all warranties expressed or implied, and no representative or person is authorized to assume any other liability in connection with the sale of our products. There shall be no claims for defects or failure of performance under any theory of sort, contract or commercial law including, but not limited to negligence, gross negligence, strict liability or breach of contract. The manufacturer declines all responsibility for damage to persons, things or animals arising from the failure to comply with the norms contained in this manual. The manufacturer reserves the right to make modifications at anytime to the models while maintaining the main characteristics described herein. The manufacturer also declines all responsibility for any errors in compiling this manual.

**WARRANTY PERFORMANCE:** During the above one year warranty period, a product with a defect will either be repaired or replaced after the product has been inspected by an LEM Service Technician. LEM RESERVES THE RIGHT TO REFUSE WARRANTY PERFORMANCE OR PRODUCT EVALUATION UNLESS THE ORIGINAL SALES RECEIPT OR THE WARRANTY CARD IS ON FILE. The repaired product will be in warranty for the balance of the one year warranty period. No charge will be made for such repair or replacement.

**IMPORTANT NOTICE:** If any parts are missing or defective, please contact our Customer Service Department for assistance at 877-536-7763. (M-F 8:30am to 4:30pm EST) **DO NOT RETURN TO THE STORE WHERE THE PRODUCT WAS PURCHASED.**

**LEM PRODUCTS MERCHANDISE RETURN POLICY WARRANTY SERVICE:**

To obtain service under terms of this warranty, please contact us at 877-536-7763 to obtain authorization prior to returning the merchandise. No merchandise will be accepted without prior authorization. Please return the product prepaid in the original packaging if possible, enclose a copy of your receipt, (Keep a copy of your proof-of purchase for your records.) and include a written explanation of the issue. Ship to LEM Products, 4440 Muhlhauser Rd., Suite 300, West Chester, OH 45011. LEM Products is not responsible for damage incurred in shipping, make certain to pack product properly. Return shipping charges are the responsibility of the purchaser. Packages returned to LEM should be insured for the value of the product to cover any damages that may occur during shipping.

Revised September 30, 2015

THE LEADER IN GAME PROCESSING



# CRAFTSMEN TENDERIZER

## USE & MAINTENANCE

682



**1 YEAR  
WARRANTY**

# ASSEMBLY & OPERATING INSTRUCTIONS

This Craftsmen Tenderizer provides an easy way to tenderize and save cooking time. The unit is made of durable stainless steel making it easy to clean and maintain. Hand operated by a crank, it is convenient, and easy to assemble and transport. The unit is built sturdy enough to be used in a restaurant or deli. The chute/hopper can tenderize meats up to 1" thick and 6 1/4" wide. The hopper opening is 6 1/4" x 1". Before using the tenderizer, please read the following instructions.

## BEFORE USE:

- Thoroughly hand wash all parts before first use in warm soapy water to remove a protective lubricant applied during manufacturing. Thoroughly dry and reassemble the unit.

## HANDLE ASSEMBLY:

- Insert the handle (#17) onto the driving shaft (#19), and fasten with bolt (#16) provided.

## CLEANING & ASSEMBLY INSTRUCTIONS:

1. Remove the bolt (#16) from the handle (#17).
  2. Remove the bolts (#16) from both sides of the cover (#1).
  3. Slide the cover up to remove from the housing (#15).
  4. Carefully slide meat combs (#20) out of knife roller assemblies.
  5. Remove the upper nylon plates (#11).
  6. Carefully lift knife assembly rollers out of the housing one at a time being careful not to touch the sharp edges of the tenderizing blades.
  7. To remove the lower nylon plates (#11A), remove the 4 housing screws (#14).
  8. After hand washing and thoroughly drying parts, reassemble unit. Spraying the unit and parts with Food Grade Silicone (available at LEM Products) before storing for long periods of time will prevent oxidation and keep the unit looking and working like new. Wash silicone spray off all parts before next use.
- Follow steps 1-8 after each use.

## WARNING AND PRECAUTION:

- Use equipment for tenderizing appropriately sized cuts of meat only.
- Be careful of the sharp blades when operating or cleaning the unit.
- Always keep the cover ON the unit when in use.
- Keep your hands at least 2" away from the blades, when feeding meat into the machine.
- **Keep this tenderizer out of reach of children.**

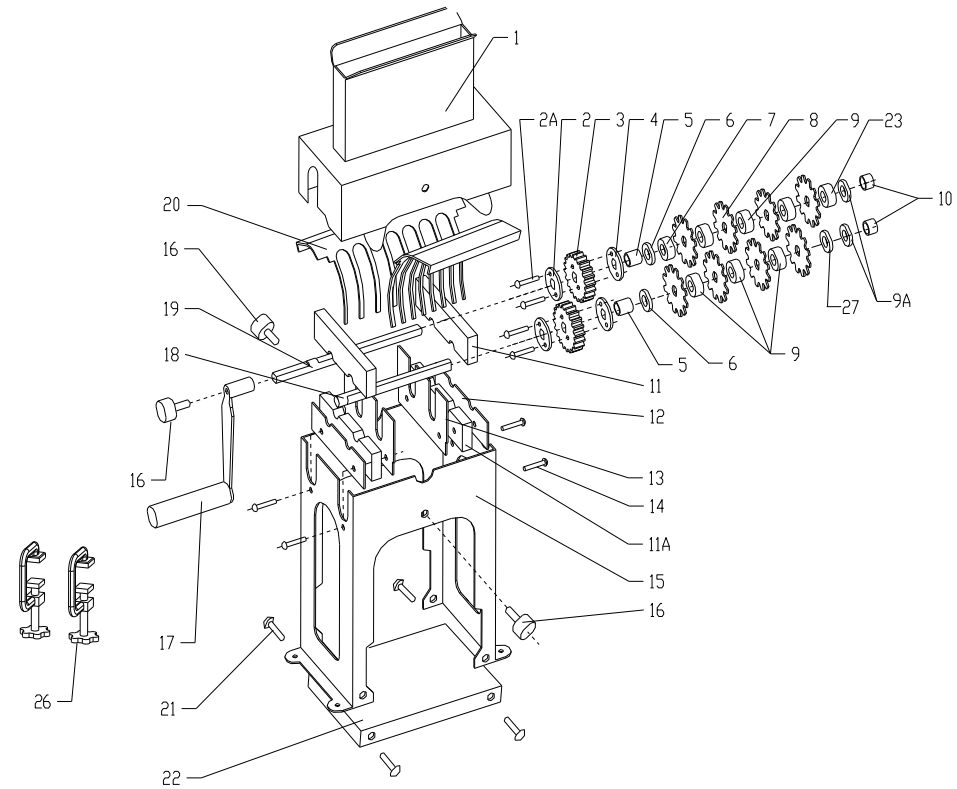

CRAFTSMEN TENDERIZER  
MODEL #682

| #   | DESCRIPTION                  | QTY | #  | DESCRIPTION                 | QTY |
|-----|------------------------------|-----|----|-----------------------------|-----|
| 1   | Cover                        | 1   | 12 | S/S Plate 1                 | 2   |
| 2   | Gear Bracket — Driving Shaft | 2   | 13 | S/S Plate 2                 | 2   |
| 2A  | Gear Bracket Screws          | 4   | 14 | Housing Screw               | 4   |
| 3   | Gear                         | 2   | 15 | Housing                     | 1   |
| 4   | Gear Bracket                 | 2   | 16 | Plastic Head Bolt           | 3   |
| 5   | S/S Sleeve (long)            | 2   | 17 | Handle                      | 1   |
| 6   | S/S Spacer                   | 2   | 18 | Driven Shaft                | 1   |
| 7   | Nylon Sleeve (short)         | 1   | 19 | Driving Shaft               | 1   |
| 8   | Knife                        | 30  | 20 | Meat Combs                  | 2   |
| 9   | Nylon Sleeve (long)          | 29  | 21 | Bolt for Base               | 4   |
| 9A  | Internal Retaining Ring      | 2   | 22 | PP Base                     | 1   |
| 10  | S/S Sleeve (short)           | 2   | 23 | Nylon Bushing (7.9mm thick) | 1   |
| 11  | Upper Nylon Plate            | 2   | 26 | C-Clamps                    | 2   |
| 11A | Lower Nylon Plate            | 2   | 27 | Nylon Bushing (3.2mm thick) | 1   |