

THE LEADER IN GAME PROCESSING



STAINLESS STEEL MEAT MIXER

USE & MAINTENANCE

733A & 734A



ATTENTION:

If any components of this unit are broken,
or if the unit does not operate properly,
please contact LEM Products at

1-877-536-7763

For more great products or a free catalog
log onto www.lemproducts.com



**1 YEAR
WARRANTY**

⚠ GENERAL WARNINGS AND SAFETY INFORMATION ⚠

IT IS IMPORTANT TO READ AND UNDERSTAND ALL OF THE INSTRUCTIONS AND SAFEGUARDS PRIOR TO USE

1. Always ensure that the appliance is properly assembled and safely set up before use.
2. **DO NOT** leave the appliance unattended if it can be switched on and operated.
3. **CAUTION:** This appliance is not recommended for use near or by children or persons with certain disabilities. Set up and store the appliance out of reach of children. When not in use, store device in a secure and dry place out of reach of children.
4. Store Appliance in upright position to extend life of motor.
5. **WARNING:** Heavy object, to avoid muscle strain or back injury, use lifting aids and proper lifting techniques when moving appliance.
6. The appliance must be connected to an 120V AC electric supply only.
7. For your safety, this unit is equipped with a 3-pronged, grounding plug and must be plugged into a properly grounded outlet. If your outlet is not of the proper type, it is your responsibility to have the outlet and wiring changed to the correct type. Do not cut off the third (grounding) prong. Do not use an adapter.
8. Using this appliance with an extension cord may cause a decrease in electrical current, causing the motor to be over worked and possibly catch fire.
9. Do not operate with a damaged cord or plug, after the unit malfunctions, has been damaged in any way or if appliance has been immersed in water or other liquid. Return unit to LEM Products for assessment and repair.
10. Always unplug unit when not in use, when changing parts or cleaning.
11. Never unplug by pulling on the power cord, always pull directly on the plug itself.
12. Do not let cord hang over edge of table or counter, contact sharp edges or touch hot surfaces.
13. Indoor use only. To protect against the risk of electrical shock, never immerse the device in water and do not expose the device to rain or moisture. **WARNING:** In the event the device should fall into water, remove the plug from the wall socket before attempting to remove the unit from the water. If submergence occurs, have the appliance examined by an authorized technician before use.
14. To protect against the risk of electrical shock, **DO NOT** use the appliance if your hands are wet or if you are standing on a wet floor. **DO NOT** use the appliance if it is wet or moist. **DO NOT** operate this device with wet hands or bare feet. **DO NOT** operate near running water.
15. The appliance is designed for domestic use and not for commercial purposes.
16. **DO NOT** use the appliance on bones, deep frozen food, hard items or non-food items.
17. Use the appliance with the supplied accessories only. **WARNING:** The use of attachments not recommended or sold by the manufacturer may cause injury, damage to personal property, and may void your warranty.
18. **WARNING:** Do not use while under the influence of alcohol or drugs (prescription or non-prescription) as these may impair user's ability to properly assemble or safely operate the appliance.
19. The manufacturer declines any responsibility in the case of improper use of this product. Improper use of this product voids the warranty.
20. Avoid contacting moving parts. Wait until all parts have come to a complete stop and disconnect from the power source before removing any parts of the appliance.
21. **DO NOT** operate the appliance without the upper case installed.
22. **DO NOT** use fingers to push meat into appliance while the unit is running, doing so may cause serious injury.
23. Thoroughly hand-wash all parts in warm soapy water prior to use. **DO NOT SOAK. NOT DISHWASHER SAFE** (discoloration may occur).
24. Tie back loose hair and clothing. Remove neckties, rings, watches, bracelets or other jewelry before operating the appliance.
25. Use on a level, stable surface to prevent tipping. Never move the appliance while in use.
26. **WARNING:** Knives are **SHARP!** To avoid injury, use extreme caution when handling.
27. When unit is turned off, cooling fan will no longer operate. **DO NOT** touch housing during cool down period. Housing will take a few minutes to cool down after unit is turned off.

28. SAVE THESE INSTRUCTIONS

IMPORTANT WARRANTY INFORMATION PLEASE READ FILL OUT AND RETURN ENCLOSED WARRANTY CARD

THIS WARRANTY COVERS:

LEM Stainless Steel Meat Mixer #733A & #734A

THE WARRANTY IS EXTENDED TO THE ORIGINAL PURCHASER ONLY

WARRANTY DURATION: This product is warranted to the original purchaser for a period of one (1) year from the original purchase date. **EACH UNIT COMES WITH A WARRANTY CARD, WHICH MUST BE FILLED OUT COMPLETELY AND RETURNED IMMEDIATELY, WITH A COPY OF THE PURCHASING RECEIPT. FAILURE TO RETURN YOUR WARRANTY CARD WILL LIMIT WARRANTY TO 90 DAYS WITH PROOF OF PURCHASE.**

WARRANTY COVERAGE: This product is warranted against defective materials or workmanship. The warranty is void if the product has been damaged by accident, misuse, neglect, modification or improper service or repairs by unauthorized personnel. It is also void if damaged in shipment or by other causes not arising out of defects in the materials or workmanship. This warranty does not extend to any units which have been in violation of written instructions furnished. This warranty covers only the product and its specific parts, not food or other products processed in it.

WARRANTY DISCLAIMERS: This warranty is in lieu of all warranties expressed or implied, and no representative or person is authorized to assume any other liability in connection with the sale of our products. There shall be no claims for defects or failure of performance under any theory of sort, contract or commercial law including, but not limited to negligence, gross negligence, strict liability or breach of contract. The manufacturer declines all responsibility for damage to persons, things or animals arising from the failure to comply with the norms contained in this manual. The manufacturer reserves the right to make modifications at anytime to the models while maintaining the main characteristics described herein. The manufacturer also declines all responsibility for any errors in compiling this manual.

WARRANTY PERFORMANCE: During the above one year warranty period, a product with a defect will either be repaired or replaced after the product has been inspected by an LEM Service Technician. **LEM RESERVES THE RIGHT TO REFUSE WARRANTY PERFORMANCE OR PRODUCT EVALUATION UNLESS THE ORIGINAL SALES RECEIPT OR THE WARRANTY CARD IS ON FILE.** The repaired product will be in warranty for the balance of the one year warranty period. No charge will be made for such repair or replacement.

IMPORTANT NOTICE: If any parts are missing or defective, please contact our Customer Service Department for assistance at 877-536-7763 (M-F 8:30am to 4:30pm EST). **DO NOT RETURN TO THE STORE WHERE THE PRODUCT WAS PURCHASED.**

LEM PRODUCTS MERCHANDISE RETURN POLICY WARRANTY SERVICE: To obtain service under terms of this warranty, please contact us at 877-536-7763 to obtain authorization prior to returning the merchandise. No merchandise will be accepted without prior authorization. Please return the product prepaid in the original packaging if possible, enclose a copy of your receipt, (keep a copy of your proof-of-purchase for your records) and include a written explanation of the issue. Ship to LEM Products, 4440 Muhlhauser Road, Suite 300, West Chester, OH 45011. LEM Products is not responsible for damage incurred in shipping, make certain to pack product properly. Return shipping charges are the responsibility of the purchaser. Packages returned to LEM should be insured for the value of the product to cover any damages that may occur during shipping.

Revised November 20, 2015

MIXING MEAT

When making sausage it is important to add water to the mixture.

Water will: 1) Help the seasoning blend with the meat better. 2) Make mixing easier. 3) Make stuffing easier. It will not weaken the flavor of the sausage.

1. Mix seasoning (and cure if used) with a minimum of 1 oz. of water per pound of meat. Mix thoroughly until seasoning is dissolved.
2. Put meat in mixer and pour water/seasoning mixture over meat. Place the tank cover (#6) on the mixer.
3. Mix meat until it starts to become tacky. DO NOT OVERMIX.
4. Remove sausage from mixer and immediately put it into stuffer for stuffing. Do not allow sausage to sit before stuffing. If mixture becomes difficult to stuff you can add water.

AFTER USE

1. Unscrew the axle-adjusting knob (#3) clockwise until the paddles disengage. The axle with paddles (#7) can now be easily removed.
2. Wash the meat tank (#1) and the axle with paddles (#7) with warm soapy water, rinse and dry thoroughly. We highly recommend the removal of the gearbox prior to washing. (See replacement of gear box.) Do not submerge the gearbox in water.
3. Lightly coat the unit with a food grade silicone spray. This will prevent oxidation and keep the mixer in like new condition. Silicone Spray is available from LEM Products.
4. Replace the axle with paddles (#7) by aligning the notch on the paddles with the axle drive shaft (#8). Align the axle bushing (#5) with the axle adjuster (#4). Tighten the axle-adjusting knob (#3) counter-clockwise to hold axle in place.

WARNINGS & PERCAUTIONS

1. When paddles are in motion do not put hands into meat tank.
2. Never operate unit without the cover being in place on the mixer.
3. Always unplug the grinder when loading or removing meat from the meat tank.
4. Keep this mixer out of the reach of children.

BEFORE USE

1. Read and understand all directions prior to use.
2. Thoroughly clean all parts before first use in warm soapy water, to remove the lubricant applied during manufacturing.
3. We highly recommend the removal of the gearbox prior to washing.
4. **DO NOT** submerge the gearbox in water.

USING THE MIXER WITH A GRINDER MOTOR

TO USE THE MIXER WITH AN LEM .75HP, 1HP, 1.3HP or 1.5HP GRINDER

Determine what type of grinder you have:

- If the grinder has a splined drive, go to: *To Attach the Mixer to the Grinder.*
- If the grinder has a slotted drive, you will have to contact LEM for a modified gearbox. Simply call 1-877-536-7763, tell the service representative you need a gearbox for a 733A/734A to work with a slotted drive motor (Part #733A-27). It will be shipped to you, along with a postage paid label for the return of the original gearbox.

To replace the gearbox:

1. Remove the 6 Phillips head screws (#14) from the gearbox cover (#13).
2. Grasp the gearbox and rock it up and down gently until it comes loose.
3. Slide the new gearbox in place.
4. Replace the 6 Phillips head screws.

To Attach the Mixer to the Grinder:

1. Unplug the grinder.
2. Thread the nuts (#18) onto each of the 4 mixer feet (#17), and then thread the mixer feet into the unit.
3. Place drive gear shaft (#12) of the meat mixer close to the drive shaft of the grinder. Adjust the mixer feet (#17) up or down until the drive gear shaft (#12) of the mixer aligns with the drive shaft of the grinder.
4. Slide the units together as tightly as possible while turning the paddles of the mixer by hand until the drive gear shaft aligns with the grinder drive shaft.
5. Tighten the nuts on the mixer feet to the bottom of the mixer to hold the unit at the desired height.
6. Tighten the star bolt on the grinder (not shown) against the mixer attachment.
7. Plug in the grinder.

PARTS LIST

Number	Description	Quantity
1	Meat Tank	1
2	Mixer Set Screws	2
3	Axle Adjusting Knob	1
4	Axle Adjuster	1
5	Axle Bushing	1
6	Tank Cover	1
7	Axle With Paddles	1
8	Axle Drive Shaft	1
9	Axle Drive Shaft Key	1
10	Axle Drive Shaft Gear	1
11	Axle Drive Shaft Spacer	1
12	3 3/8" Drive Gear Shaft	1
13	Outer Gear Box Cover	1
14	Phillips Head Screws	6
15	Handle (for Splined Shaft)	1
17	Mixer Foot and Bolt (5 1/2")	4
18	Mixer Foot and Bolt Nut	4
19	Axle Drive Seal	1
20	Inner Gearbox Cover	1
21	Outer Drive Shaft Bearing	1
22	Inner Gearbox Cover O-Ring	1
23	Axle Adjusting Knob O-Ring	1
24	Roller Bearing (6002 GB)	2
25	Axle Drive Shaft Bearing (6906 GB)	1
**	Gearbox for Slotted or Splined Drive	

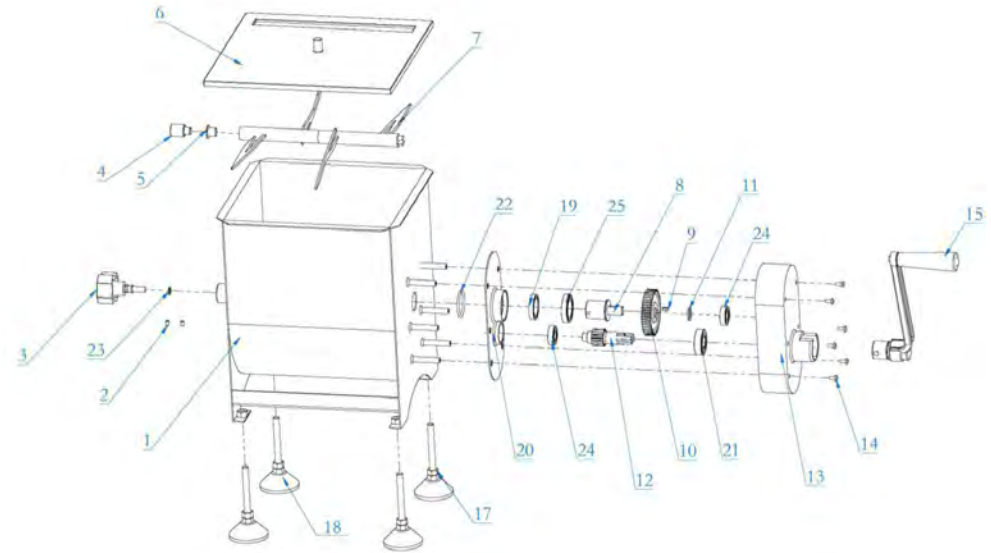

1 If the mixer does not attach to your LEM grinder, then call 877.536.7763 to request a gearbox with a 4" drive shaft (Part#733A-26).

** A complete gearbox for a slotted drive (Part#733A-26) or splined drive (Part#733A-27) grinder is available for order.